

Half stepping techniques

By operating a stepper motor in half stepping mode it is possible to improve system performance in regard to higher resolution and reduction of resonances. It is also possible to reduce torque variations to achieve an even smoother motion and more precise positioning by modifying the half step mode.

The electronics and programming, as well as the theoretical background involved in generating the necessary signals for half stepping using New JRC's stepper motor drivers are described in this application note.

The rotating magnetic field

The basic principle of driving the stepper motor is to generate a rotating magnetic field to which the rotor aligns. The rotating field is generated in the stator by currents in the two phase windings (see figure 1). The direction and the magnitude of the magnetic field is described in a vector diagram (see figure 2). To create a two dimensional vector at least two coordinates have to be controlled—the X- and the Y-axis coordinates. In the following these X and Y axes are also referred to as the stator axes.

The two windings in figure 1 generate a magnetic flux which is aligned to the two stator axis. The current ratio between the two windings gives the total magnetic field vector its direction and the length of the vector represents the added magnetic flux amplitude. These vectors is shown both in figure 1 and 2. The torque at the shaft (axis) is proportional to the magnetic field.

Referring to figure 1: If phase A and B are energized, the rotor can step from position 1 to position 3, 5, 7 and so on in either direction, depending on the magnetic flux direction which is controlled by the current direction in the two windings. This drive is normally referred to as "two-phase-on" drive. If only one stator coil is energized at a time the rotor can step from position 2 to 4, 6, 8 and so on. This drive mode is referred to as "one-phase-on" drive. Both of these two drive modes will result in full stepping, but the full step positions are shifted one half of a full step.

Half stepping

If these two drive modes are combined and correct sequences are fed into the windings the rotor can be made to align at all positions i.e. 1, 2, 3, 4, and so on. This is referred to as "half-step mode".

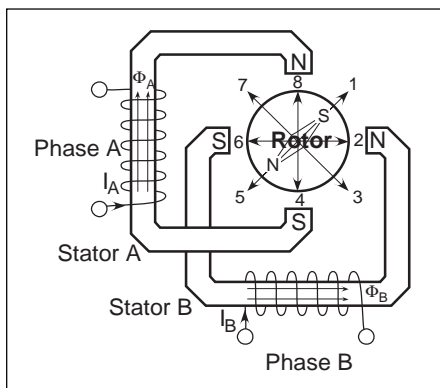

Figure 1. Two phase stepper motor.

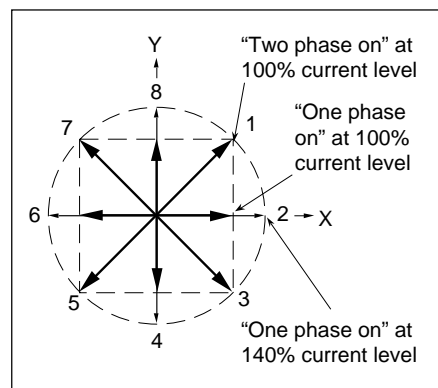

Figure 2. Direction and amplitude of the magnetic field.

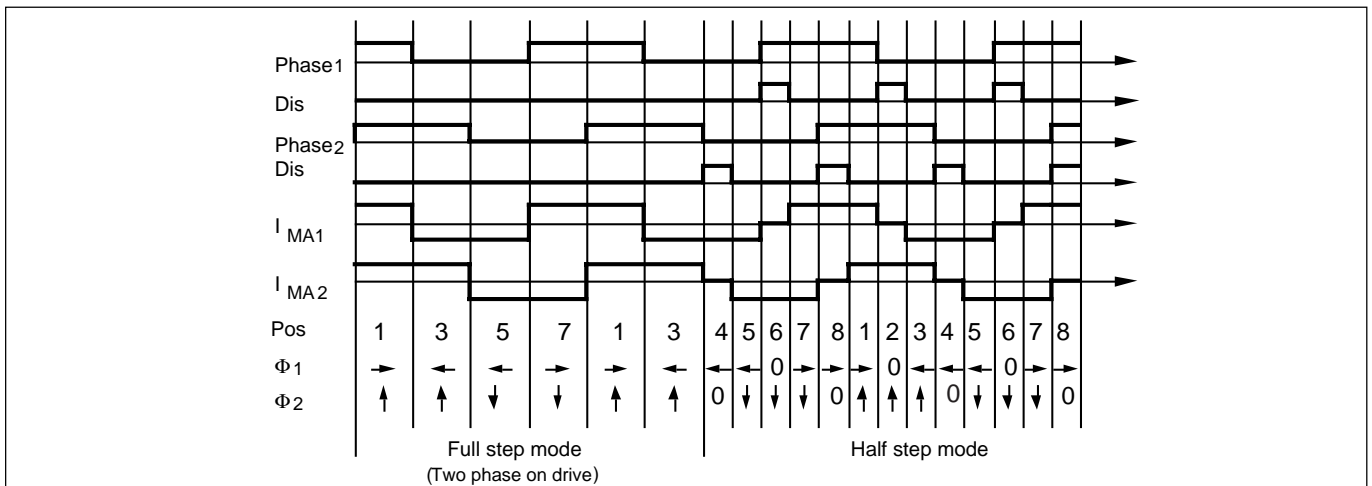

Figure 3. Input signals, output current and magnetic field direction for the different rotor positions in figure 1.

Figure 3 describes the current time diagram, it includes input signals and a current direction table as well as the magnetic field direction.

The first part shows the two-phase-on drive where the motor steps from pos 1 to 3, 5, 7. In the second part of the diagram, a half step sequence is fed into the windings.

Compared to full-step drive, half-step drive gives some major advantages:

- Higher resolution (without use of a more expensive motor with higher number of steps).
- Less problems with resonance phenomena. Resonances appear as a sudden loss of torque at one or more stepping rates.

Half stepping usually overcomes these resonance problems.

However a disadvantage with half-step drive is a significant torque variation. The reason is the torque in one-phase-on positions is about 70% of the two-phase-on positions' torque. This variation can cause vibrations and/or mechanical noise, though less than in full-step drive mode.

Modified half stepping (constant torque mode)

The way to deal with this torque variation problem is to increase the one-phase-on position torque, to achieve a constant torque over all positions. This can be done if the current level is increased to approximately 140% of the nominal two-phase-on current, in the half-step positions (i.e. 2, 4, 6, 8 in figures 1 and 2).

This is done by changing the value of R_s and/or V_{ref} . The currents in the two-phase-on positions are then reduced by changing the V_{ref} . Some circuits (like the NJM3717 and NJM3770A) have the ability to set different current levels internally via the I_0 , I_1 logical inputs. These inputs set the current to 100%, 60%, 20% and 0% of the maximum current. Note that 140% current level is a theoretical figure. If the application demands very accurate torque and/or the smoothest-possible drive, the relative current levels between full- and half-step positions may have to be adjusted, depending on the type of motor and step rate used.

Since the current is increased every half step, the total power dissipation as well as the torque is kept at a constant level (the same level as in full-step mode of 100% current). Increasing the current to 140% is obviously not always possible without exceeding maximum current or P_D ratings of the driver circuit.

However, when using New JRC's dual-channel drivers, this is not a problem. The performance of the driver is limited by the package and the allowable power dissipation. When both channels are on, a certain amount of power is dissipated, and, if one of the channels is shut off, the power dissipation is reduced by 50%. The other channel is therefore allowed to dissipate more power and consequently drive more current.

Single drivers can be selected to match the highest current level needed, i.e. the 140% current level, in one-phase-on position, since they can not share the package power handling capability.

Current decay

It is very important to consider the current behaviour when entering the one-phase-on position. Especially when using half-step drive. To force the rotor into one-phase-on position the current through the non-energized coil should be brought to zero as quickly as possible. Often fast current decay will result in a reduction of the vibrations and resonances. But the performance achieved is very much dependent on the application (mechanical damping, the lag between the rotor position and the magnetic field and so on). Fast current decay will "tighten up" the control of the magnetic field versus the input phase.

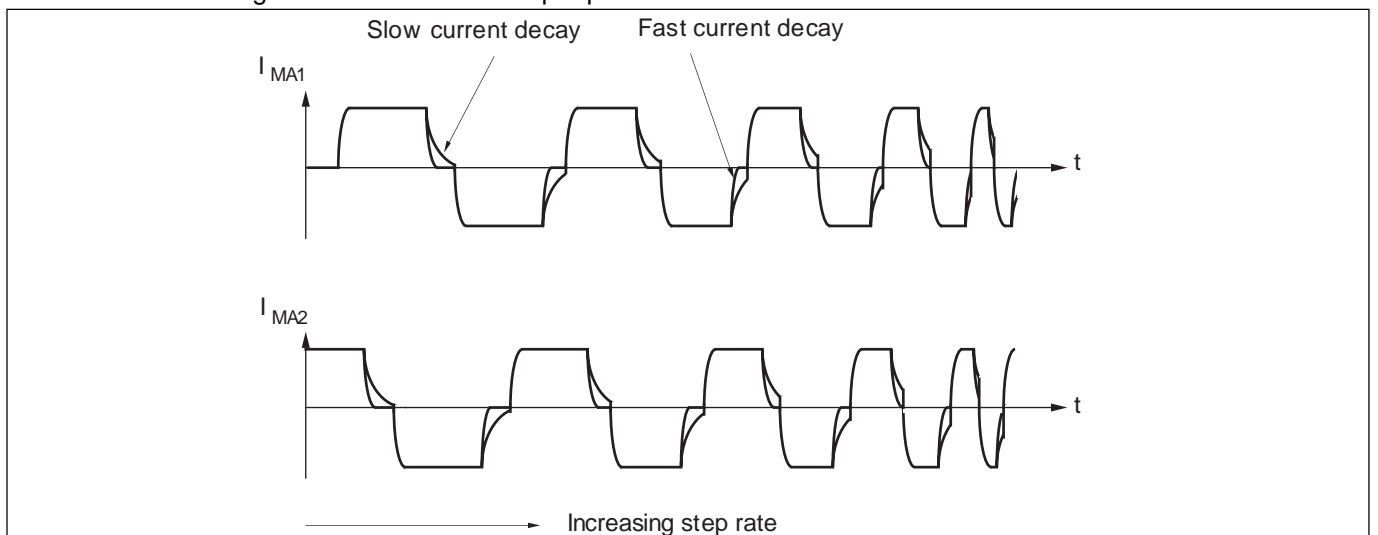

Figure 4. Fast and slow current decay effects on the motor current vs. increasing step rate.

By current decay, we are referring to the current change which occurs when de-energizing the coil completely after a phase shift, not the current decay during constant current switching. Generally the current decay time is dependent on the voltage into which the winding discharges its stored magnetic energy. Forcing the remaining current to flow back into the power supply, which is the highest available voltage in the application, results in the fastest possible current decay.

Figure 3 shows an idealized picture of the motor current. A more-realistic picture is illustrated in figure 4. At high step rates, it is obvious that the motor current will not reach zero in the one-phase-on position if the current decay is slow, instead the motor current will be smoothed and look more and more like a distorted sine wave. The result is a significant loss of torque at high stepping rates.

In an H-bridge arrangement the current decay can be controlled by switching the transistors on and off in the right sequence. Referring to figure 5, path 1 is enabled when feeding current through the winding. Transistors Q1 and Q4 are conducting, Q2 and Q3 are shut off. Switching the output off can be done in two ways with different results.

If only Q4 is switched off, the current is forced to follow path 2. This means slow current decay—as the current is opposed only by the forward voltage drop of one diode. The major share of the stored magnetic energy is dissipated in the resistance of the motor winding. This switching method is usually used in constant-current switching. (Also referred to as two-quadrant drive).

An alternative is to shut both Q1 and Q4 off, i.e. all four transistors are shut off. This means the current is forced to flow through two diodes and the motor supply, against the supply voltage (path 3 in figure 5). This results in fast current decay. When current is recirculating in path 3, transistors Q2 and Q3 may be turned on with very little effect on the recirculating current. However, when the current is brought to zero, the current will start to flow in the opposite direction, i.e. a complete phase shift occurs. (Also referred to as four-quadrant drive).

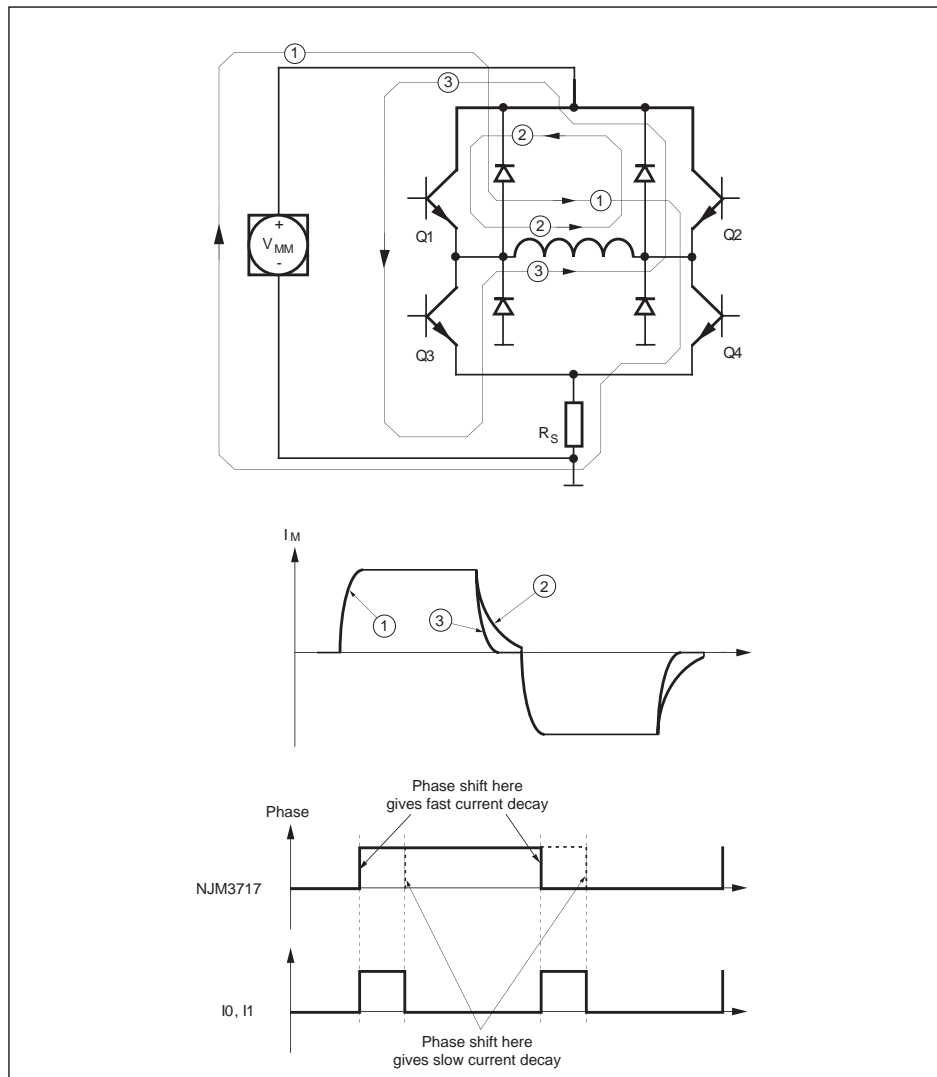

Figure 5. Output stage with current paths at turn-on, turn off and phase shift. Current behaviour at different current paths.

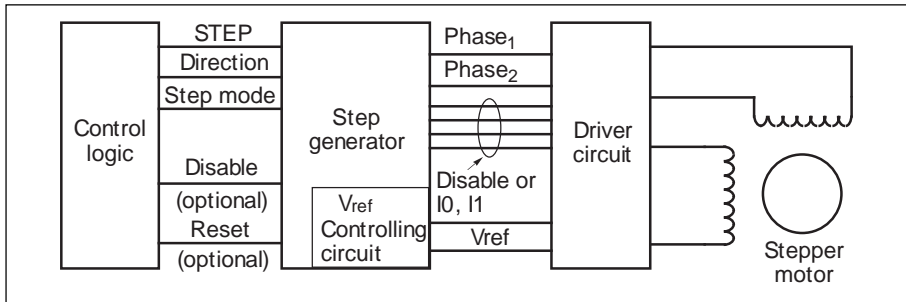

Figure 6. Definition of input and output controlling signals needed.

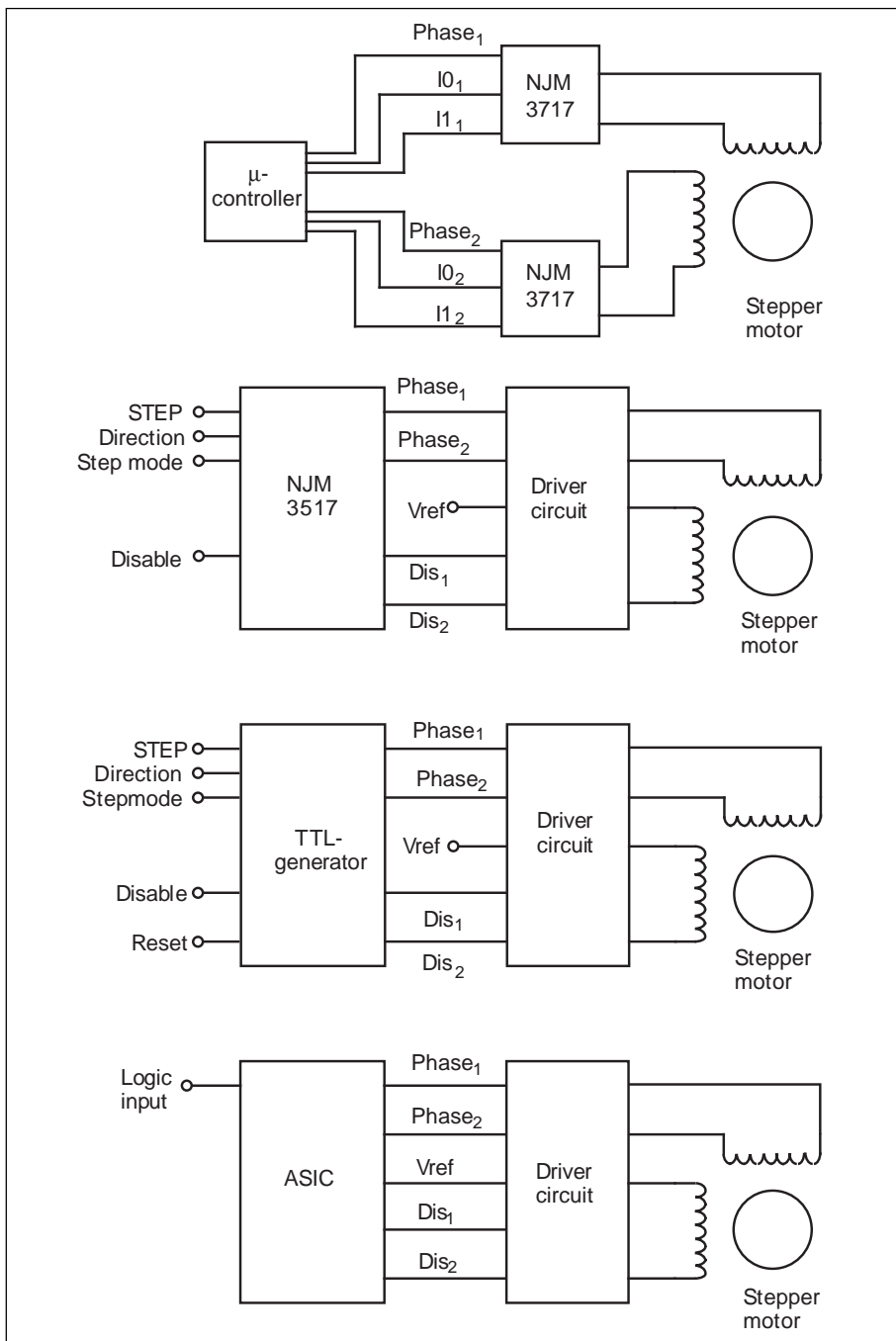

Figure 7. Examples of stepper motor driver/generator configurations.

Note: In modified half step mode the fast current decay is only applicable on the current decay from 70% level to zero current. The current decay between 100% and 70% current level will always be slow, because the only change made is lowering of V_{ref} and this will not affect the current decay.

Different circuits have different input signals to obtain fast current decay:

- NJM3717. The current is brought to zero by bringing I_0 and I_1 high, which turns off the two lower transistors Q3 and Q4. Fast current decay is achieved by simultaneously shifting the phase input which turns off the previously conducting upper transistor Q1 or Q2 (see figure 5).
- NJM3770A turns off all four transistors when $I_0=I_1=1$.
- NJM3771 turns the output transistors off when the V_R pin is brought to zero.
- NJM3772 controls the current decay via proper phase shift. See NJM3717.
- NJM3773/74/75 have a separate disable pin which turns all four transistors at the output off.

Generating the half step sequence

The step sequence is generated by a step generator which can be created in various ways. Some different step generators are presented—the intent is to give some ideas, not to present a complete list—other designs can be found by a designer, which may be application specific or even general solutions.

A block design defining the input and output pins of the step generator is shown in figure 6.

Input signals to the step generator are:

- STEP. The stepping clock signal.
- Direction. A logic input controlling the stepping direction (rotation) of the motor.
- Step mode. This is a logic input which chooses between full-, half-, and modified-half-step drive mode

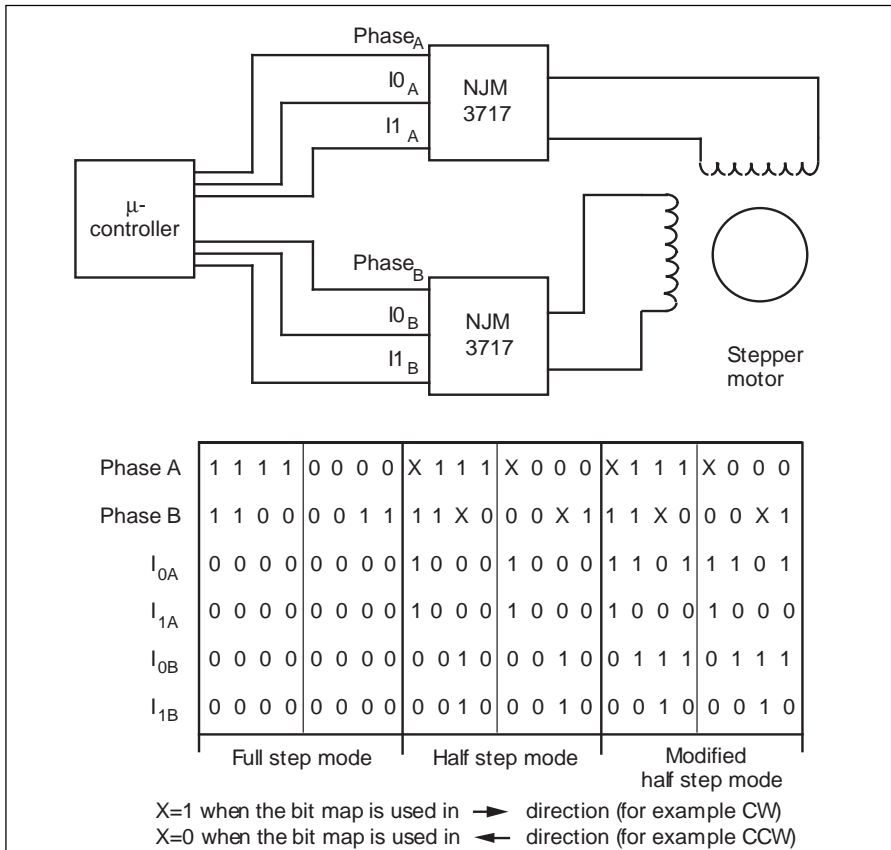

Figure 8. Two NJM3717 controlled by a microprocessor and an output bit map. Note, the change in the digital sequence when changing direction. The X values in the figure will generate fast current decay; reverse X-polarity to get slow current decay.

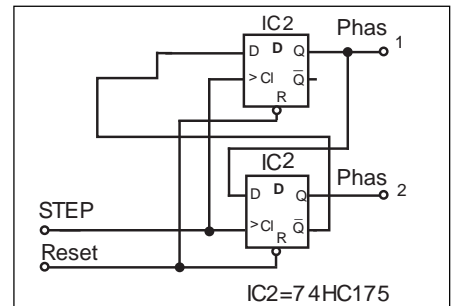

Figure 9. One direction TTL full step generator.

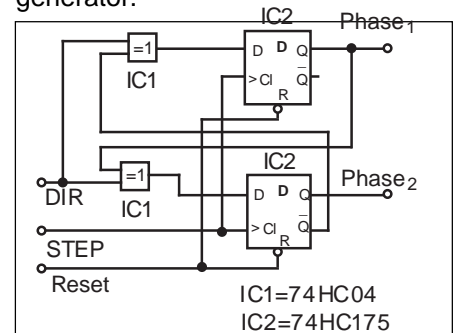

Figure 10. Two direction TTL full step generator.

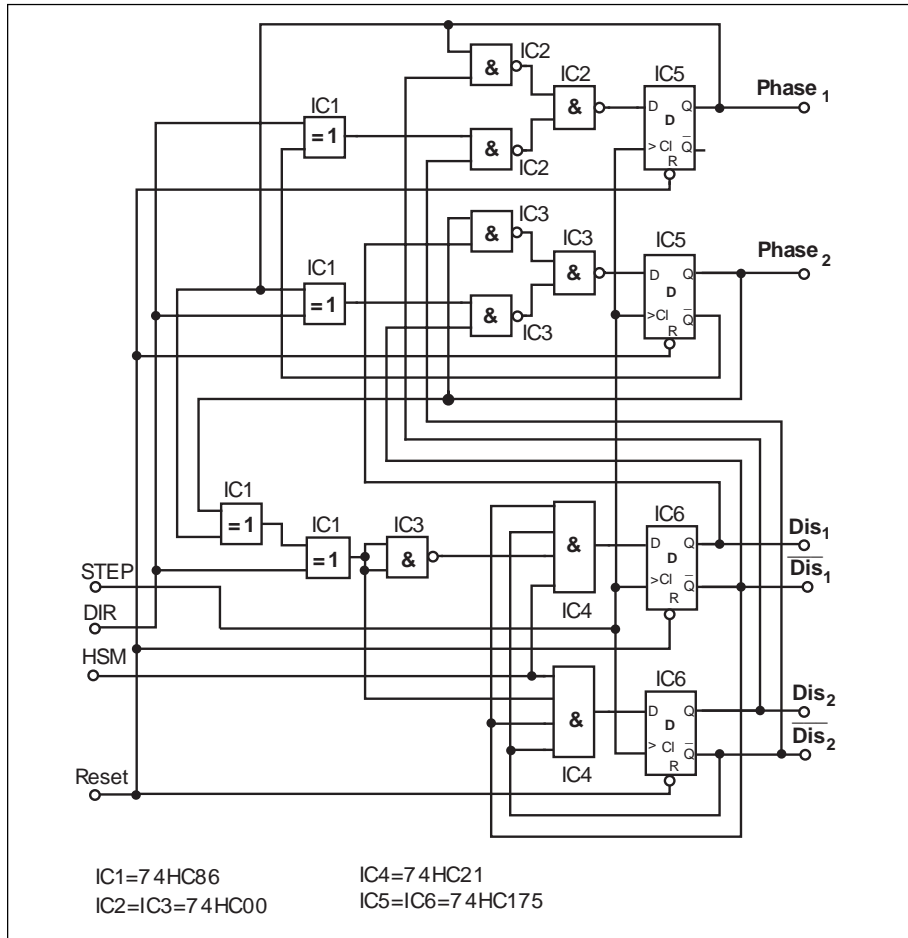

Figure 11. Two direction TTL full and half/modified half step generator.

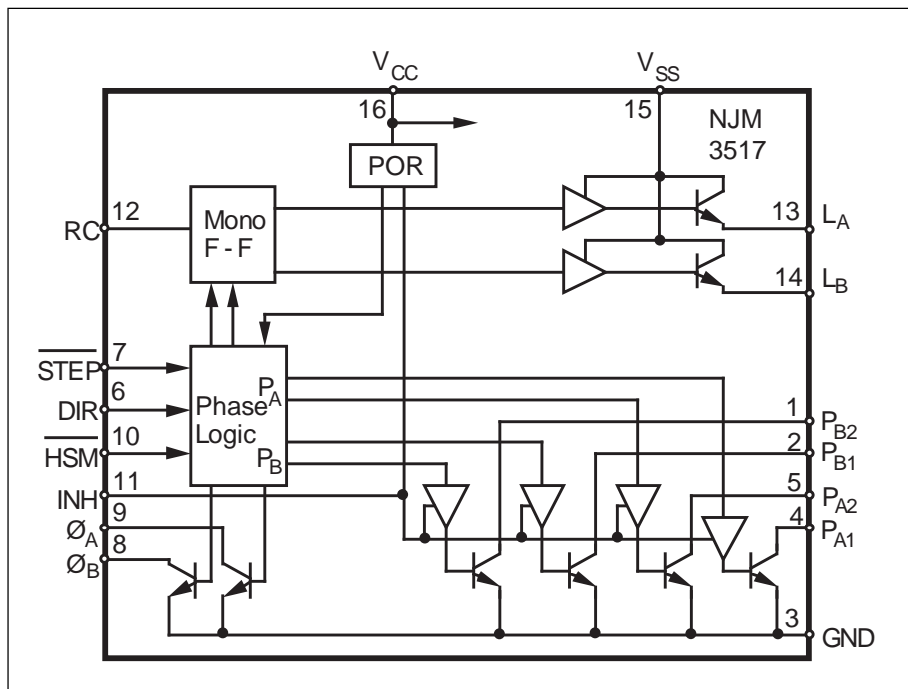

Figure 12. NJM3517 block diagram.

The output signals from the step generator are defined by the chosen driver circuit. Phase 1 and 2 are always needed, but the remaining signals depend on driver and drive mode used.

- V_{R1} , V_{R2} . These are the reference voltage inputs. They set, together with the current regulation circuit in the driver, the amount of current in the motor windings. To achieve modified-half-step drive, by changing V_{ref} , a control circuit is usually necessary.

Drivers like the NJM3717 and NJM3770A have internally-generated current levels, which could be used in half-/modified-half-stepping modes. These levels are controlled via logic control inputs I_0 I_1 .

Some examples of stepper motor driver/generator configurations are illustrated in figure 7. More details are given later.

- A software step sequence generator in a microcontroller.
- A TTL step sequence generator, designed using a few standard components.
- NJM3517 unipolar stepper motor driver can be used as a stepping sequence generator.
- An ASIC circuit can be used to generate the step sequence. This is a space saving solution which can be made application specific.

The choice between these different ways of implementing a half-/modified-half-step sequence generator has to be made considering economy, space and already-existing logic functions.

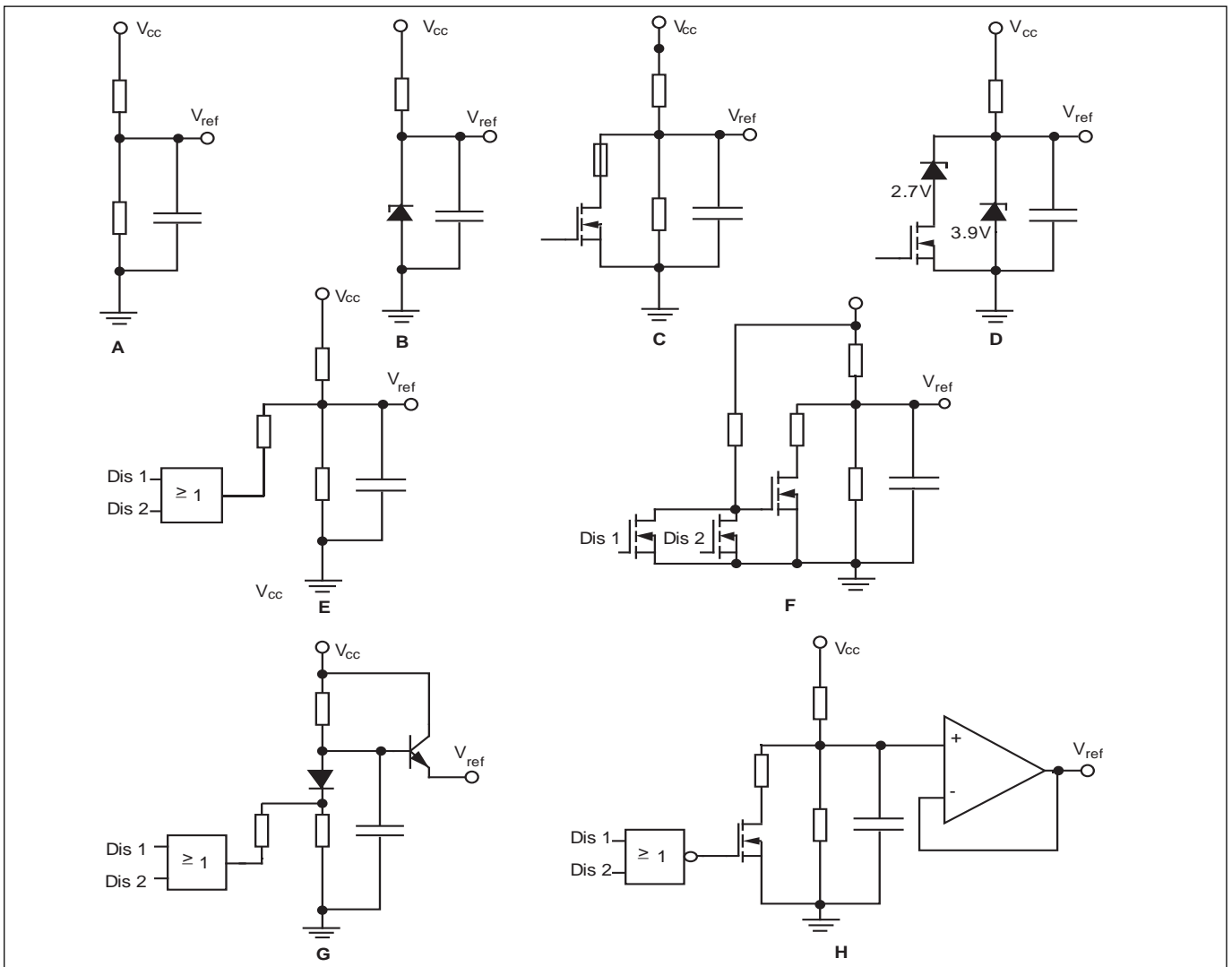

Figure 13. Examples of different voltage reference circuits.

Microcontroller as half step generator

A microcontroller is an easy way to achieve the half step control sequence. The price for a simple microcontroller is reasonably low, which means that it is cost effective in many applications. Furthermore, it is very easy to change the control signals using the software.

There are several ways to use the microcontroller output. One is to attach the driver inputs to the outputs of the controller (see figure 8) and let the controller send something like the digital sequence illustrated in the figure and access the drivers via the database. Another way is to use a latch.

Some microcontrollers have D/A converters on-chip which makes it possible to use the controller to generate and control the V_R input along with the other inputs. This gives the ability to achieve a half-step sequence with highly accurate torque.

Full step TTL-generator

A full-step TTL generator is easy to implement. A basic design is shown in figure 9. Only two D-flip-flops and one inverter are used. This design does not allow a change of stepping direction. Changing the actual rotational direction of the shaft is easily done by switching the phase outputs to one coil of the stepper motor. Only a step-signal is necessary to control the generator and the motor will take a step for each one of the pulses on the input STEP signal.

If the ability to change the rotational direction via logic signals is necessary, the design in figure 10 can be used. Here two TTL-circuits are needed. Depending on the state of the logic direction signal the motor will run in either direction.

The reset signal sets the logic outputs to zero. Note: the actual motor shaft position is not reset to a specific position and the windings are fully energized.

Half step TTL-generator

An extended TTL-generator, which can generate control signals for full step, half step and modified half step, is shown in figure 11. In some step modes and with some drivers it might be necessary to add a few components, such as voltage controlling circuits when using modified-half-step mode. The inputs in this case are step, direction and half-step mode.

As in the full-step TTL-generator above, the reset signal only sets the logic outputs to a well defined specific state. A current-disable function can be added by adding a few logic functions.

NJM3517 as a half step generator

The NJM3517 unipolar stepper motor driver can be used as a half-step generator (see figure 12). It should only be used with NJM3770A, NJM3773, NJM3774 and NJM3775. NJM3517 is not suitable to control NJM 3717, because no fast current decay is generated when entering the one-phase-on position.

NJM3770A has the fast current decay function built in via the I_0 , I_1 inputs. In NJM3773/74/75 the disable pins turns the output transistors off which causes fast current decay.

ASIC

If an ASIC circuit (PAL, PLD, Semicustom and so on) is used in the application, it will be well-suited to include the step generator. This is a very economical way of implementing the step generator, since it will occupy very little space on the ASIC chip.

Voltage reference control circuits

As discussed earlier, modified half-stepping operation requires a changing current level.

In one-phase-on positions, the current has to be about 40% higher than two-phase-on positions. Or conversely, the total current level could be brought up to the 140% level and reduced to the 100% level in the two-phase-on positions. This method is described in the following text.

To increase the total current level, the current-sensing resistor value should be lowered accordingly. When using the stepper motor drivers which have 2.5 V as nominal reference voltage, it is possible to raise the V_{ref} to increase the motor current. Or you may use a combination of lowering R_s and increasing V_{ref} . Do not exceed the maximum allowable current of the driver. Assuming V_{cc} (5 V) is used as reference voltage source, the controllable reference voltage will range well below V_{cc} .

The input reference voltage range differs within the New JRC stepper motor driver family.

NJM3717, NJM3770A and NJM3775 have an input range of 0 – 5 V. This range is not possible when using V_{cc} as V_{ref} source. To compensate for the reduced voltage range, the current sensing resistor must be lowered even more to maintain the current level.

When using NJM3717 and NJM3770A the internal 60% current levels can be used to lower the current level in the two-phase-on position. In this case an external reference circuit is not necessary, V_{CC} can be used directly.

NJM3771, -72 and -74 have a nominal V_{ref} of 2.5 V, which makes it easier to generate a suitable V_{ref} from V_{CC} . These circuits have no I_0 , I_1 inputs, therefore the current reduction in full-step positions has to be generated via the V_{ref} input when using modified-half-step mode. Different kinds of V_{ref} controlling circuits are shown in figure 13.

The comparator inputs of NJM3773 (VR and C) are of high impedance and low current (typically $-0.2 \mu A$). This gives a great deal of flexibility in selecting a suitable voltage divider network.

When using a microcontroller to generate the step sequence, it is natural to use a DAC to generate the V_{ref} . This is probably the best solution because it gives ability to easily change the V_{ref} with software.

Figure 13 illustrates a variety of voltage reference circuits that can be used, depending of the drive mode and the driver circuits used. A and B are two types of stable reference circuits.

- A. Ordinary voltage divider circuit. Using only a few components, but relying on the accuracy and stability of V_{CC} . Note, the V_R input resistance of the New JRC stepper motor circuit has a tolerance of about 20% at $25^\circ C$ and is temperature dependent.
- B. Another way is to use a zener diode to set the voltage reference. Compared to A the zener diode solution reduces the influence of the varying internal resistance. Zener diodes however are available only in a few discrete values below 5 V. Also note the indistinct zener knee and relatively high internal resistance for zener diodes at this voltage range.
- Some voltage reference controlling circuits intended for modified half step drive are illustrated in fig C-H. In this drive mode the V_{ref} voltage has to shift between two different levels.
- C. This circuit uses a MOS FET device to switch a resistor in parallel with the voltage divider, and thereby causes a reference voltage change. A capacitor at the output improves noise rejection.
- D. By using Zener diodes instead of resistors, the influence of the internal resistance can be reduced. Note the zener limitations in circuit B.
- E. When using the TTL-controller or the NJM3517, this reference circuit can be used to change the reference voltage. To reduce the influence of the input resistance, the current through the voltage divider has to be fairly high. Make sure the gate can sink the current needed. It is possible to parallel two or more gates to increase the current sink capability. Note that the gate has to be of open-drain or open-collector type.
- F. This circuit uses three FET-transistors to form an OR function. The voltage-setting circuit is a straight forward voltage divider. A capacitor on the output improves noise rejection.
- G. This is a recommended reference voltage controlling circuit. It is an ordinary voltage divider that can switch between two levels when a resistor is added in parallel with the lower resistor. Since a buffer is added at the output the current needed is fairly small. This means, the switching device can be a TTL or a CMOS gate (open drain or open collector type). The buffer is a transistor used in open emitter mode. To compensate for the base emitter temperature dependence a diode is added in the voltage divider.
- H. This reference controlling circuit uses an operational amplifier as a buffer. The voltage-setting circuit is a switchable voltage divider. A MOS transistor in conjunction with a NOR gate is used for switching. Any other voltage setting circuit can be used with an operational amplifier as buffer.

Modified half step using TTL-generator and NJM3717 or NJM3770A

This application (figure 15) uses the previously described TTL-generator (see figure 11) to generate the necessary phase signals. To set the relative current levels between the “two phase on” position and the “one phase on” position, the internal current limiting function is used. This function is controlled via the I_0, I_1 inputs.

The internal current limiting function can control the output current in four levels 100 %, 60 %, 20 % and off. In this application the 100 % and 60 % current levels are used. These levels are not optimal since the current in the “two phase on” position should be 70 % of the current in the “one step on” position. The 60 % level is used which is often adequate.

The reset signal sets the flip-flops in a defined state. This state does not shut the motor current off. To be able to turn the current off the design in figure 14 can be added to the TTL-generator. It should be placed inside the dotted boundary in figure 15.

As a voltage reference V_{CC} (5 V) is used. NJM3770A together with the chosen current sensing resistor, $R_s = 0.5 \Omega$ the motor current will be set to approximately 800 mA.

NJM3717 uses a current sensing resistor $R_s = 1 \Omega$, which gives a motor current of approximately 415 mA. These current levels can of course be changed, within the power limit, according to the application.

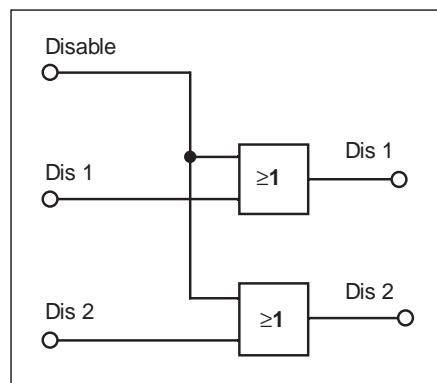

Figure 14. Motor current disable circuit.
To be included in figure 15.

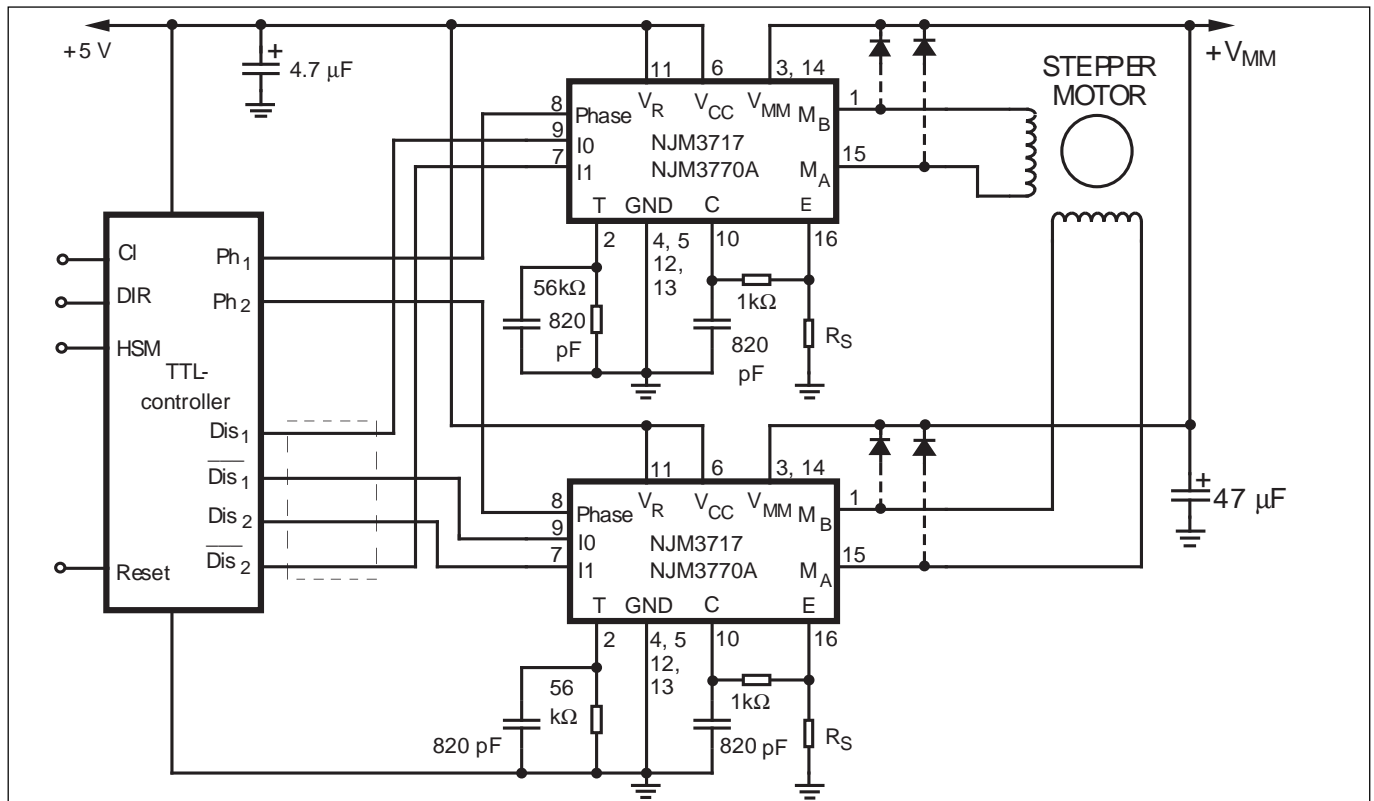

Figure 15. Typical application using a TTL controller and two NJM3717 or two NJM3770A.

Half/modified half step using TTL-generator and NJM3774

The TTL-controller shown previously (see figure 11) can be used to control the NJM3774 dual stepper motor driver circuit.

By using the disable inputs of the NJM3774 it is easy to achieve a half stepping function (see figure 17). To generate the necessary reference voltage a zenerdiode of 2.7 V is used. In the diagram a resistor of 0.68 Ω is used for current sensing. This resistor together with the reference voltage gives a peak current of 0.71 A.

To obtain modified half-stepping, a reference voltage switching circuit has to be added.

The voltage reference circuit uses the V_{CC} (5 V) as input. To achieve the two voltage levels the voltage divider G, presented in the reference voltage circuit chapter (is used, see figure 16). This reference circuit uses a voltage divider R1 and R2 to generate the reference voltage. By adding resistor R3 in parallel with R2 a change of voltage is achieved. A transistor used as a buffer reduces the influence of the input impedance. It also makes it possible to choose relatively high values of the resistors (R1, R2 and R3) to reduce current consumption. This makes it possible to use an open drain or open collector NAND gate as a switch. The diode will reduce the temperature dependence of the base emitter junction at the transistor. The motor current is easily set by changing the sensing resistor values.

The reset input at the controller resets only the internal flip-flops and does not disable the motor current. To make it possible to disable the motor current the simple circuit shown in figure 17 has to be added to the diagram in figure 18. This circuit is made up of two OR-gates. When the Disable input is high both Dis inputs at the driver are high and the currents in both windings are shut off.

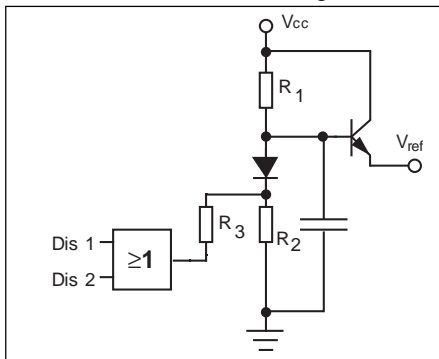

Figure 16. Voltage reference circuit to achieve modified half stepping in the application in figure 18.

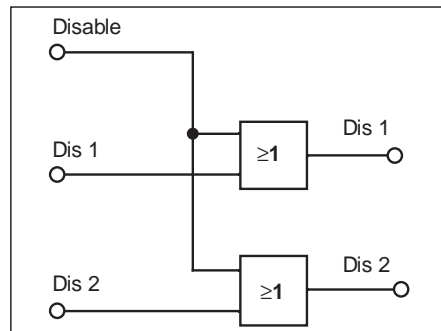

Figure 17. Motor current disable circuit. To be included in figure 18.

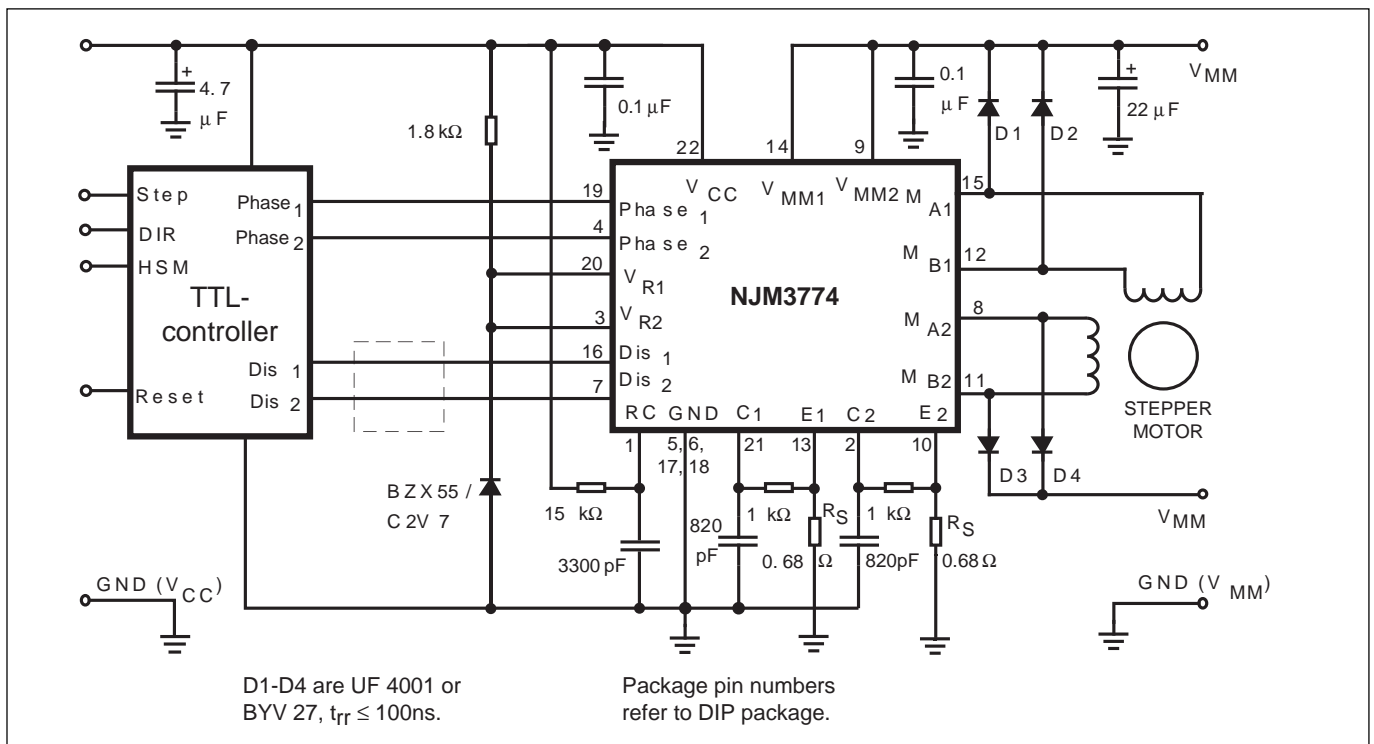

Figure 18. Typical application using a TTL controller and NJM3774.

Half stepping using NJM3770A as driver and NJM3517 as controller

With this configuration it is easy to achieve half stepping. The unipolar stepper motor driver NJM3517 can be used as a step controller. Not all of the stepper motor driver circuits are perfectly suitable to function together with NJM3517 (see the Generating step sequence chapter).

Figure 20 shows an application where the NJM3517 controls and generates the step sequence for two NJM3770A. The NJM3517 includes both a full step and a half step sequence generator and the choice between the two is easily made via the logic input, Full/Half step. The Direction input controls the rotational direction of the motor shaft. The Step input controls the step rate.

The $\emptyset A$ and $\emptyset B$ outputs of the NJM3517 are used as current controlling signals for the NJM3770A (I_0 and I_1) pins (see figure 20). The phase inputs are controlled directly from the PA1 and PB1 outputs of the NJM3517. Since the outputs from NJM3517 are open collector outputs pull-up resistors are needed.

With a current sensing resistor (R_s) of 0.5Ω a motor current of 800 mA is achieved. Note: The NJM3770A has fast current decay if both I_0 and I_1 are brought to logic high. This is because all four output transistor are shut off.

To achieve modified half stepping the logic circuit in figure 19 has to be incorporated. I_0 , I_1 are used to lower the current in the "two phase on" positions. This will result in lowering the current to 60%. This is not optimum but will be accurate enough in most cases. Furthermore this includes a disable function which turns the outputs off.

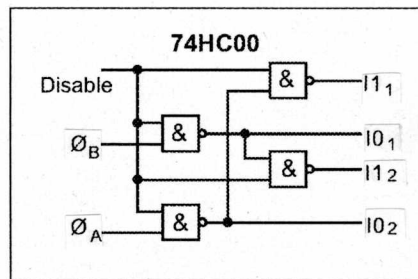

Figure 19. Circuit to achieve modified half stepping in the application in figure 19.

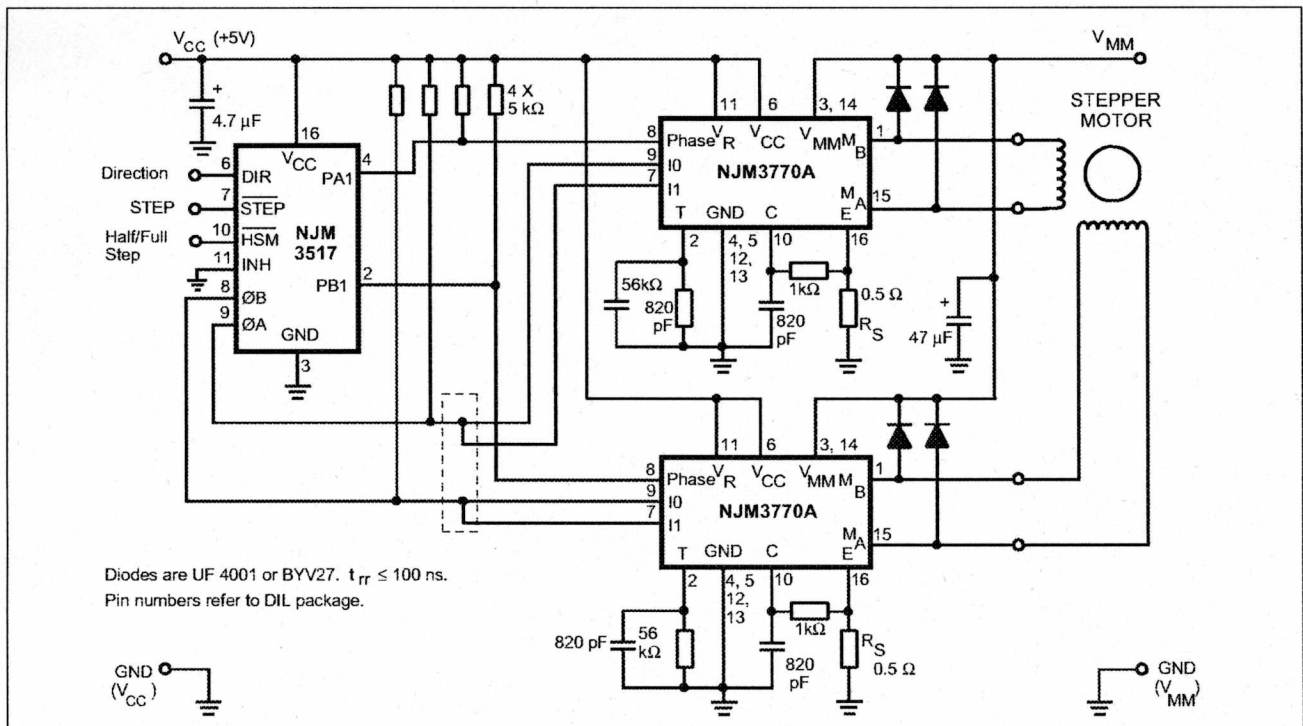

Figure 20. Typical application using NJM3770A as driver circuit and NJM3517 as controller circuit.

Half stepping using NJM3774 as driver and NJM3517 as controller

With this configuration it is easy to achieve half stepping. The unipolar stepper motor driver NJM3517 can be used as a step controller. Not all of the stepper motor driver circuits are perfectly suitable to function together with NJM3517 (see the Generating step sequence chapter).

Figure 21 shows the diagram wired for half stepping. To generate the necessary reference voltage a zener diode of 2.7 V is used. In the diagram a resistor of 0.68 Ω is used for current sensing. This resistor together with the reference voltage gives a peak current of 0.71 A.

To achieve modified half stepping the reference voltage must shift between two levels. The higher level at “one phase on” and the lower level at “two phase on”.

The voltage reference circuit uses the V_{CC} (5 V) as input. To achieve the two voltage levels the voltage divider G, presented in the reference voltage circuit chapter, is used (see figure 21). This reference circuit uses a voltage divider R1 and R2 to generate the reference voltage. By adding a resistor R3 in parallel with R2 a change of voltage is achieved. A transistor used as a buffer reduces the influence of the input impedance. It also makes it possible to choose relatively high values of the resistors (R1, R2 and R3) to reduce current consumption. This makes it possible to use an open drain or open collector NAND gate as a switch. The diode will reduce the temperature dependence of the base emitter junction at the transistor.

The motor current is easily set by changing the sensing resistor values.

To make it possible to disable the motor current, a simple circuit shown in figure 22 has to be added to the diagram in figure 23. This circuit is made of two OR-gates. When the Disable input is high both Dis inputs at the driver are high and the currents in both windings are shut off.

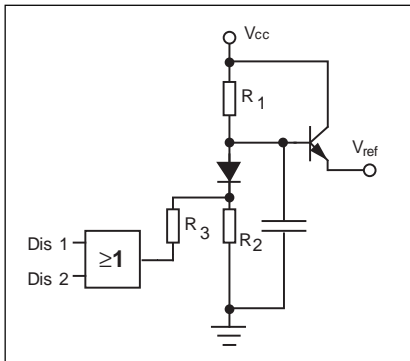

Figure 21. Voltage reference circuit to achieve modified half stepping in the application in figure 21.

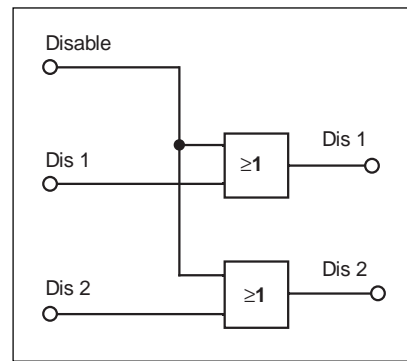

Figure 22. Motor current disable circuit. To be included in figure 21.

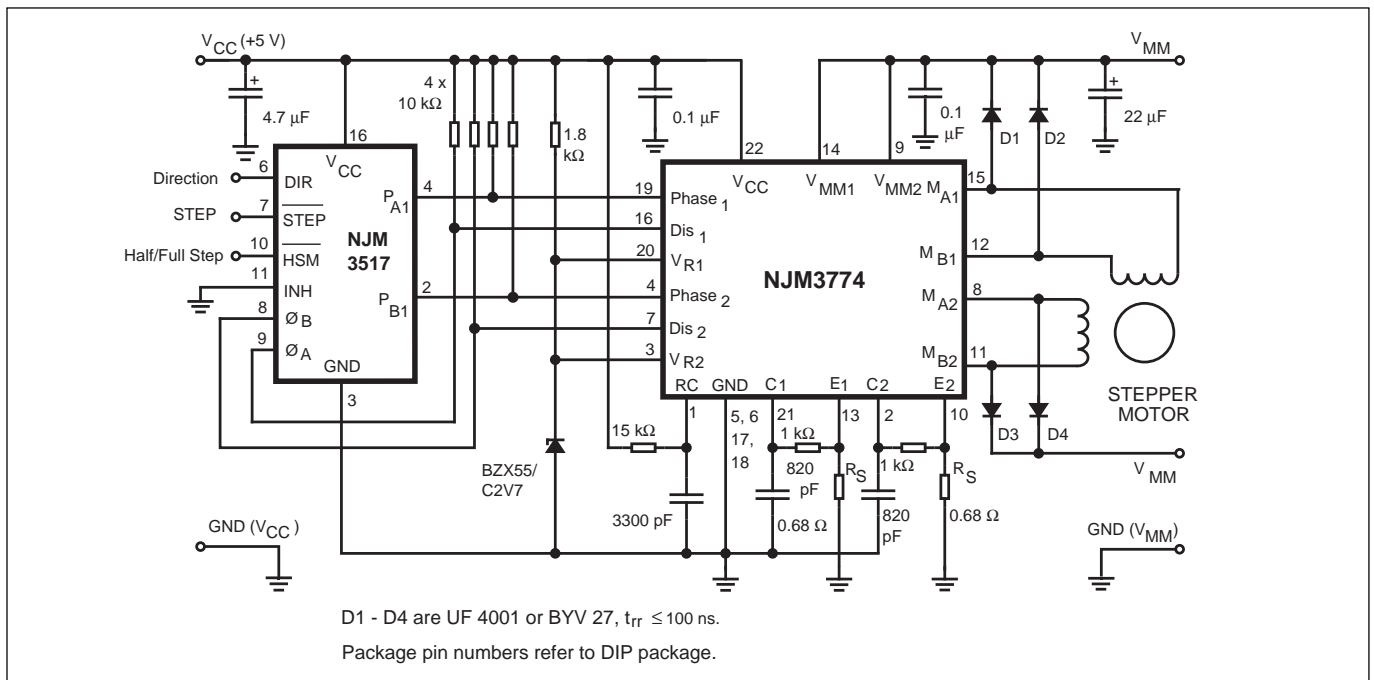

Figure 23. Typical application using NJM3774 as driver circuit and NJM3517 as controller circuit.